



A S T A

AeroSpace Technologies  
of Australia Pty Ltd  
(Incorporated in ACT)

226 Lorimer Street  
Port Melbourne 3207  
Victoria Australia

Telephone (03) 647 3111  
Telex AA 34851  
Fax (03) 645 3424

25th August, 1989

Transmittal Letter Reference No. 179

SUBJECT: NOMAD ALERT SERVICE BULLETIN ANMD-53-9

Alert Service Bulletin ANMD-53-9 is issued to rectify a reported defect, whereby a bolt in the rudder pedal assembly caught on the pedal guard and seal assembly, causing the rudder pedal to jam in the forward position. The aircraft was on the ground at the time, with no serious consequences. An in-flight occurrence could have resulted in a far more dangerous situation. The brush seals and their sealing stripes are removed from the rear faces of the pedal guards and relocated on the front faces, so giving increased clearance between the offending bolt and associated pedal guard.

Please include this SB and the new SB Index into your Service Bulletin Manual.

*Asw*

SALES AND MARKETING SUPPORT  
MANAGER



# Nomad

## ALERT SERVICE BULLETIN

Reference No. 179

FUSELAGE - RUDDER PEDAL GUARD -  
RELOCATION OF BRUSH SEALS (MOD N728)

1. PLANNING INFORMATION

A. Effectivity

(1) Aircraft Affected

All N22 Series and N24 Series aircraft whose log-books do not already record compliance with this Alert Service Bulletin (ANMD-53-9) or Mod N728.

(2) Spares Affected

Not Applicable

B. Reason

The bolt connecting the Brake Actuating Arm to the Pivot Arm caught on the Pilot's RH Rudder Pedal Upper Guard causing the pedal to jam in the forward position.

Implementation of this Alert Service Bulletin (ANMD-53-9) gives increased clearance and relieves this potential hazard.

C. Description

The upper and lower brush seals and their retaining strips are removed from the rear, or hidden faces of the rudder pedal guards, and re-located on the front, or visible faces. Attaching rivets are flush countersunk on the rear faces of the guards.

D. Compliance

Compliance with this Alert Service Bulletin shall be accomplished before the next 100 hours TIS following receipt of this bulletin.

Page No	1	2	3	4	5	6	7	8	9	10	11	12	13	14	15	16	17	18	19	20
Rev No	-	-	-	-																



# *Nomad*

## ALERT SERVICE BULLETIN

E. Approval

The modification detailed herein has been approved pursuant to Civil Aviation Regulation 35 and conforms with type certification requirements.

F. Manpower

2 manhours per aircraft.

G. Material - Price and Availability

Not Applicable

H. Tooling

Not applicable.

J. Weight and Balance

Nil effect.

K. References

Defect Report; ASTA Drawing N-10-1564.

L. Publications Affected

N22 and N24 Series

MM - Chap 27-20-04 Page 204, Para 2 A (6)

IPC - Chap 53-20-02, Fig 1, Items 11, 12, 15, 16, 19, 20, 23 and 24

IRM - Part 1, Page 3

2. ACCOMPLISHMENT INSTRUCTIONS

- A. Install External Rudder Gust lock.
- B. Remove Upper and Lower rudder pedal guards from each side of the footwells of each crew position.
- C. Remove the brush seal and retaining strips from each guard by drilling out the attaching rivets.



# Nomad

## ALERT SERVICE BULLETIN

- D. Countersink the holes for the attaching rivets on the rear face of the guards (i.e. the hidden face when the guard is installed).
- E. Chamfer the edges of the curved slot on the rear face, approximately 0.03 inch by 45 degrees. Do not chamfer the end radii of the slot.
- F. Re-attach the brush seals and retaining strips using rivets such that the seals and retaining strips are now on the front face of the pedal guards, and the rivet tails are flush riveted in the countersinks on the rear face. (Refer Fig. 1)

NOTE: Damaged seals or retaining strips should be replaced with new items.

- G. Re-identify reworked guards as per para 3B.
- H. Replace the pedal guards.
- J. Remove the external Rudder Gust lock, and check the pedals for free movement throughout their full travel and range of adjustment.

### 3. MATERIAL INFORMATION

- A. Parts required per aircraft.

The following parts are to be supplied from Operator's stocks or from local sources.

<u>Part No</u>	<u>Title</u>	<u>Qty</u>
MS24070AD3-3	Rivet	80

- B. Parts modified and re-identified by the Operator

<u>Part No</u>	<u>Nomenclature</u>	<u>New P/N</u>
3/N-10-745	Guard, Rudder Pedal, Upper, I/B, LH	3/N-10-745/NMD-53-9
3/N-10-746	Guard, Rudder Pedal, Upper, I/B, RH	3/N-10-746/NMD-53-9
5/N-10-749	Guard, Rudder Pedal, Lower, I/B, LH	5/N-10-749/NMD-53-9



# Nomad

## ALERT SERVICE BULLETIN

<u>Part No</u>	<u>Nomenclature</u>	<u>New P/N</u>
5/N-10-750	Guard, Rudder Pedal, Lower, I/B, RH	5/N-10-750/NMD-53-9
4/N-10-757	Guard, Rudder Pedal, Upper O/B, LH	4/N-10-757/NMD-53-9
4/N-10-758	Guard, Rudder Pedal, Upper, O/B, RH	4/N-10-758/NMD-53-9
5/N-10-751	Guard, Rudder Pedal, Lower O/B, LH	5/N-10-751/NMD-53-9
5/N-10-752	Guard, Rudder Pedal, Lower O/B, RH	5/N-10-752/NMD-53-9

#### 4. RECORDING ACTION

Record compliance with Service Bulletin NMD-53-9 in the Airframe Log Book.

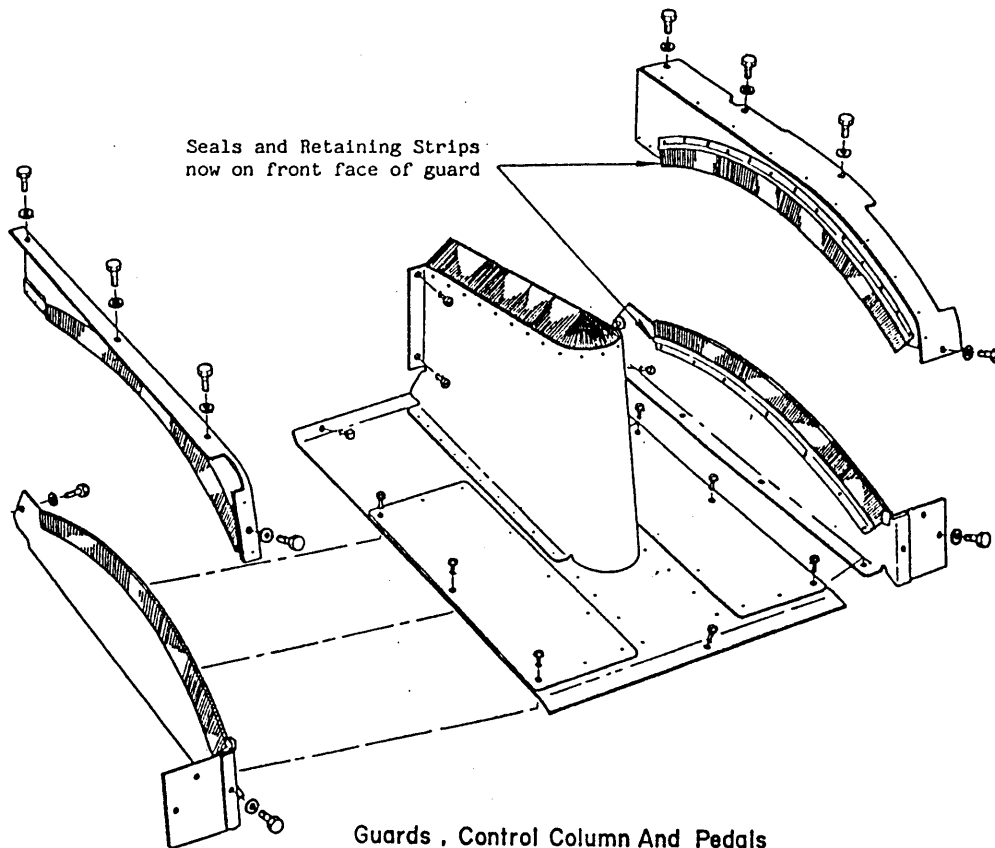

Guards, Control Column And Pedals  
LH/RH  
Figure 1